

P20™ Service Manual

Table of Contents

| | |
|--|-----------|
| General Instructions | 1 |
| Cleanliness | 1 |
| Cautions | 1 |
| Exploded View and Parts List | 2 |
| P20™ Disassembly Instructions | 3 |
| P20™ Assembly Instructions | 8 |
| Part Replacement Guide | 13 |
| Tool List | 14 |
| Lubrication and Oil Recommendations | 15 |
| Oil Cleanliness | 17 |
| Recommended Start-up Procedure | |
| for New or Rebuilt Pump or Motor | 17 |
| Recommended Test Procedure | 18 |
| Instructions for Rotation Change | 20 |

P20™ Pump Service Instructions

General Instructions

These service instructions will familiarize you with the P20 series roller bearing pump - its component parts and their relative position - proper methods for disassembly and assembly - care and use of this hydraulic pump - so that you can prolong the life of your pump as well as operate the P20 at maximum performance.

We recommend that you read this entire set of instructions before attempting any repair.

It is a good idea to check all replacement parts closely before installing to insure that damage did not occur during their shipment.

Cleanliness

Since "DIRT" is the enemy of any hydraulic system, a requirement of a good maintenance system is cleanliness. **MAKE SURE YOU DISASSEMBLE AND ASSEMBLE YOUR HYDRAULIC EQUIPMENT IN A CLEAN AREA.**

TO PREVENT PERSONAL INJURY SAFETY GLASSES AND STEEL TOE SHOES SHOULD BE WORN.

Cautions

1) Commercial Intertech's replacement parts are made to original equipment standards. For assured quality of material and workmanship and for compatibility in assembly, **USE ONLY GENUINE COMMERCIAL REPLACEMENT PARTS.**

2) If prying apart castings becomes necessary, take extreme caution not to mar or damage the machined surfaces. Excessive force while prying can result in misalignment and seriously damage parts.

3) If parts are stubborn during assembly, do not force them and never employ an iron hammer.

4) Gears are closely matched, therefore, they must be kept together as a set when removed from the unit. Handle with care to avoid damage to the journals, faces, and teeth.

5) Never hammer roller bearings into bores. Use only an arbor press or other suitable tool.

6) It is important to airblast all parts and wipe them down with a clean lintless cloth before assembly.

Exploded View and Parts List

- | | |
|---------------------------|----------------------------|
| 1) Lip seal | 10) Gear housing |
| 2) Shaft end cover | 11) Port end cover |
| 3) Checks (2) | 12) Washers (4) |
| 4) Ring seals (2) | 13) Cap screws (4) |
| 5) Bearings (4) | *Not required on all units |
| 6) Thrust plates (2) | 14) *Outboard bearing |
| 7) Pocket seal strips (2) | 15) *Spiral lock |
| 8) Section seals (2) | |
| 9) Gear set | |

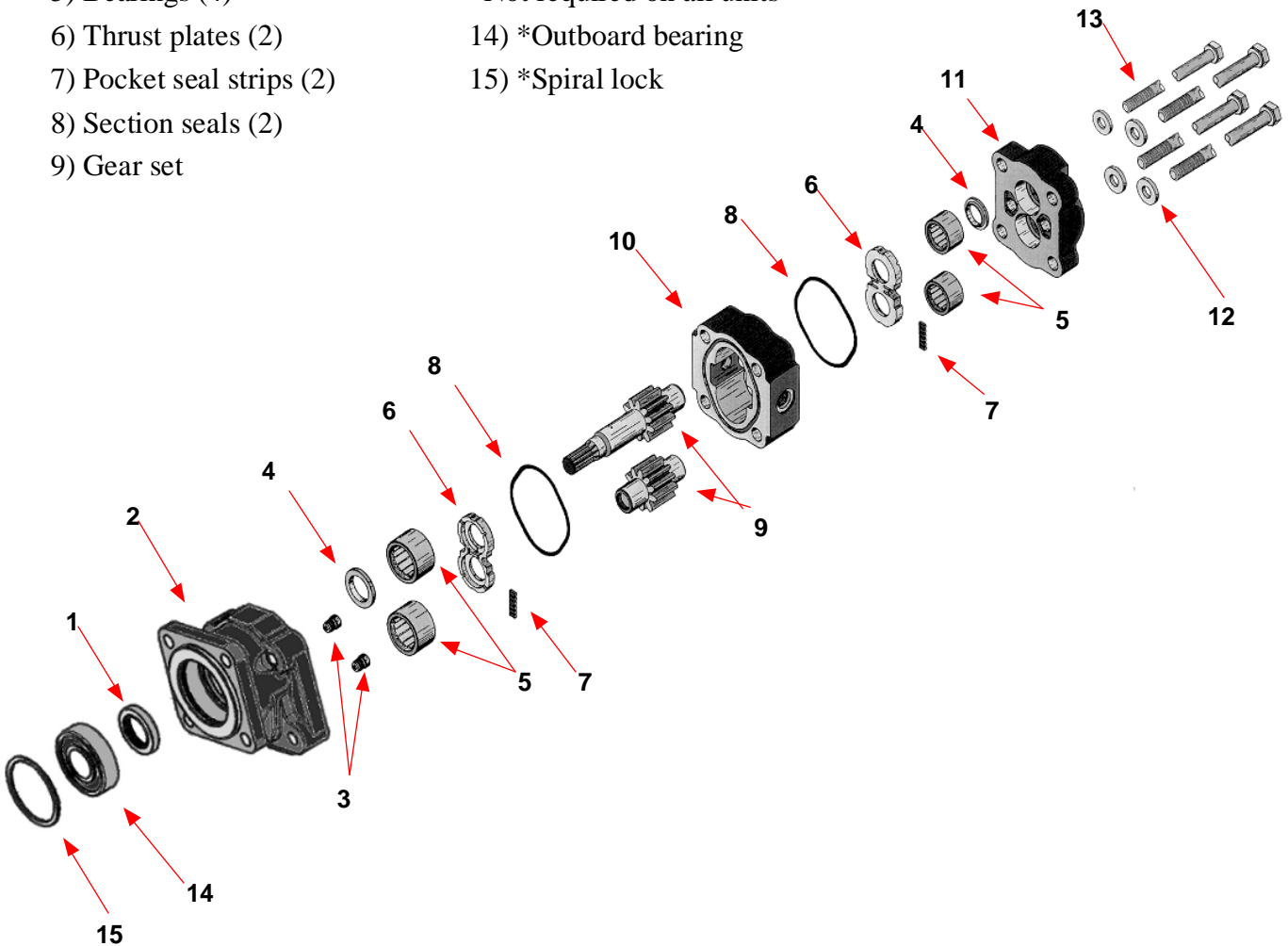

P20™ Disassembly Instructions

Step 1

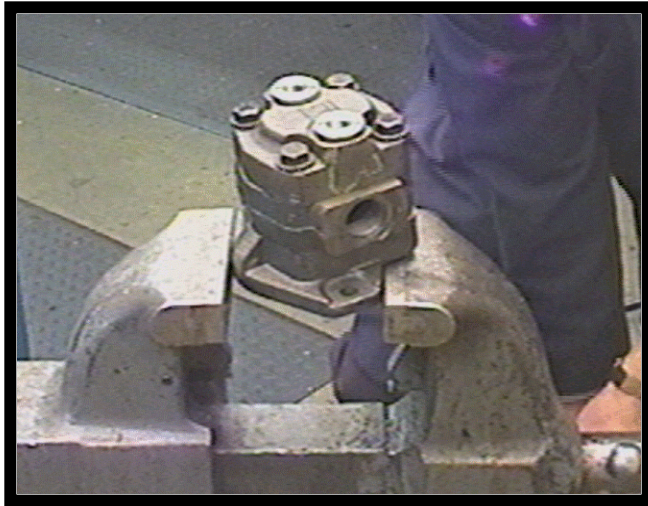

Place the pump in a vise with the drive shaft pointing down. Clamp unit on the sides of the mounting flange. Do not clamp on the pilot diameter as it may damage the sealing surface.

Step 2



Mark each casting in the assembly with machinist's ink or a prick punch to orient the castings so unit can be reassembled later in the proper position.

Step 3



Loosen and remove the four cap screws and washers with a 13/16" socket and wrench.

Step 4.1



Remove the port end cover subassembly using steps 4.1 through 4.3:

- 4.1 Place the point of a large screw driver or a chisel on the parting line between the port end cover casting and the gear housing casting. Gently tap until some separation between the castings is detected.

P20™ Disassembly Instructions

Step 4.2



4.2 Place two large flat bladed screwdrivers into the separation notches and pry up the port end cover until loose.

BE CAREFUL not to nick, mar, or scratch the machined casting faces.

Step 4.3



4.3 Lift off the port end cover sub-assembly .

Step 5.1



Remove the gear housing subassembly using steps 5.1 through 5.3:

5.1 Place the two large flat bladed screwdrivers into the separation notches and pry up the gear housing until loose.

BE CAREFUL not to nick, mar or scratch the machined casting faces.

Step 5.2



5.2 Lift off the gear housing sub-assembly.

P20™ Disassembly Instructions

Step 5.3



5.3 Remove the thrust plate from the housing. It may be necessary to gently tap the thrust plate with the handle of a hammer or screw driver. Be careful not to bend or score the thrust plate. Remove and discard the six small rubber pocket seals from the thrust plate.

Step 6



Remove and discard the rubber section seals from the top and the bottom gear housing faces.

Step 7



Wipe the gear face surface dry with a clean lint free cloth. Mark the teeth of the gear set at their mesh point with machinist's ink or quick dry marker. This is to index the gear set for proper orientation during reassembly.

Step 8



Remove the idler gear and the gear shaft. Keep them together as they are a matched set. Handle with care to avoid damage to the journals, faces, and teeth.

P20™ Disassembly Instructions

Step 9



Gently lift off the thrust plate. Be careful not to bend or score the plate and mating surface of the casting. Remove and discard the six rubber pocket seals from the back of the thrust plate.

Step 10



Remove the lip seal. Place a lip seal removal tool (see Tool List on page 14) or a screw driver tip against the inside of the lip seal and tap the screw driver handle with a hammer. Be careful not to damage the roller bearing or the ring seal with the screw driver tip.

Note: If the bearings are going to be removed from the casting, then this step can be performed after Step 12.

Step 11



Use a bearing puller to remove the roller bearings.

Note: This step is optional depending on the condition of the bearings.

Step 12



Remove the bronze ring seal from the gear shaft bearing bore in the shaft end cover and the port end cover castings.

P20™ Disassembly Instructions

Step 13



Remove the checks from the shaft end cover casting with the check tool (see Tool List on page 14).

CAUTION: Failure to follow the recommended assembly instructions can result in poor performance or failure of the product. Product should be thoroughly tested to ensure proper operation before the unit is put back into service.

P20™ Assembly Instructions

Step 1



Stone all machined casting surfaces with a medium grit carborundum stone. If the bearings were removed, deburr the bearing bore using a deburring tool. Rinse all parts in a solvent fluid. Air blast all parts and wipe them clean with a clean lint free cloth before starting the assembly.

Step 3

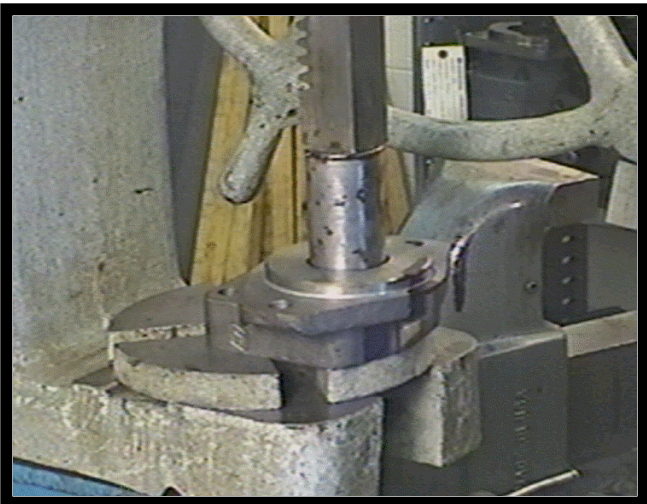

Place the shaft end cover on an arbor press with the pilot facing up. Place the lip seal, with the shoulder of the seal up, at the top of the seal bore. Press the lip seal into the shaft end cover with a lip seal installation bar (see Tool List on page 14). The seal should be pressed in so it is flush with the recessed face in the shaft end cover casting.

Step 2



Coat the outside diameter of the lip seal with Permatex Aviation Form-A-Gasket No.3 Non-Hardening Sealant or equivalent.

Be careful not to get Permatex on the inner lip of the seal as it will cause a lip seal leak.

Step 4



Apply Loctite® No.262 to the threaded check holes in the shaft end casting. Install the checks in the shaft end cover using the check tool (see Tool List on page 14).

The checks must bottom out in the casting.

P20™ Assembly Instructions

Step 5



Peen over the check holes in the shaft end cover with a 1½” steel ball and a hammer. This will insure that the checks do not back out of the check holes during operation.

Step 6



If the ring seals were removed from the shaft end cover or the port end cover, they should be replaced at this time. Place the ring seals in the bottom of the drive gear bearing bores. Be sure that the flat side of the ring seal is against the mating surface in the casting. Ring seals are placed behind the drive gear bearings only.

Step 7



Install the bearings in the shaft end cover and the port end cover. Use an arbor press to press the bearings into the bottom of the bearing bores. Check to make sure the ring seals move freely under the drive gear bearings.

Step 8



Grip the shaft end cover in a vise with the mounting face down. Cut two pocket seals 7/32” long from the pocket seal strip. Grease the seals well and insert them into the center slots on the reverse side of the thrust plate.

P20™ Assembly Instructions

Step 9

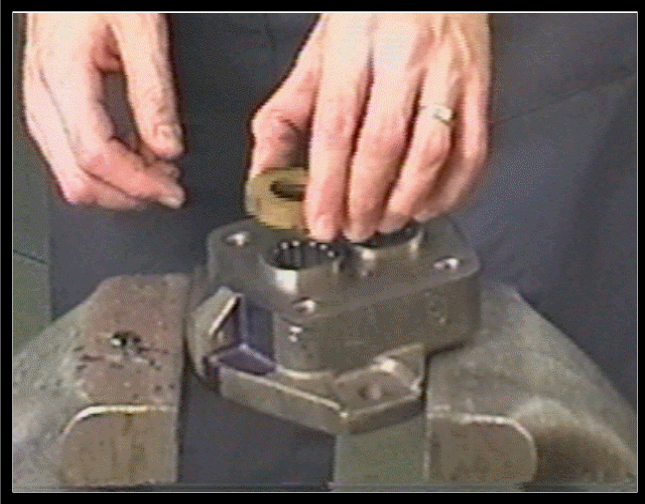

With the pocket seals facing down, place the thrust plate over the bearings. Tap the thrust plate with a soft faced hammer around the edge until the thrust plate is about 1/32" from the casting surface. **Do not tap the center of the plate.** Cut four pocket seals 1/4" long from the seal strip. Push a pocket seal into each of the remaining slots in the thrust plate until it touches the bearing wall. Use a razor blade to trim the exposed portion of the pocket seals. The pocket seals should be flush with the O.D. of the plate.

Step 10



Insert the external drive end of the gear shaft into the shaft installation sleeve (see Tool List on page 14). Lightly grease the gear shaft and sleeve.

Step 11



Insert the gear shaft with the shaft installation sleeve into the shaft end cover using a twisting motion. Be careful not to damage the lip seal. Push down carefully until the gear rests against the thrust plate face. Remove the shaft installation sleeve. Insert the idler gear into its bearing bore matching the orientation marks on the teeth of the drive and driven gear as previously marked (see Step 7 on page 5).

P20™ Assembly Instructions

Step 12

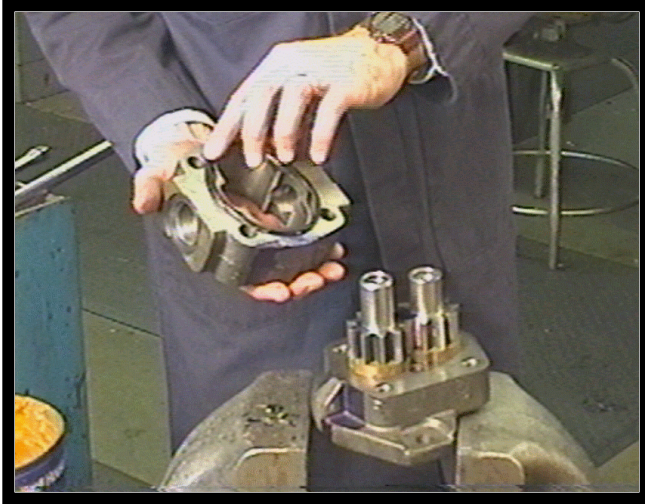

Apply a light coating of grease to the new section seals and place them into the machined grooves on both sides of the gear housing. Check the section seals for proper fit.

Step 14



Insert the pocket seals into the thrust plate and install onto the port end cover following the previous instructions in steps 8 and 9. Then place the port end cover over the gear journals. The orientation mark on the PEC must line up with the mark on the gear housing. Also, be sure that the bearing bore holding the ring seal goes over the drive gear journal. Apply pressure to the casting with your hand or tap lightly with a soft faced hammer until the port end cover rests tightly against the gear housing.

Step 13



Locate the orientation mark on the gear housing and line it up with the mark on the shaft end cover. Slide the gear housing over the gear set. Make sure that the gear housing rests tightly against the shaft end cover. Be careful not to pinch the section seal.

Squirt clean hydraulic oil over the gear shaft and the idler gear to provide initial lubrication when the pump is started.

P20™ Assembly Instructions

Step 15



Thread the four cap screws with the washers into the shaft end cover and tighten them in a cross corner pattern. Rotate the gear shaft of the pump with a 6" wrench to make certain there is no binding in the pump.

Step 16



After the cap screws are tightened and you are sure there is no internal binding, tighten the cap screws in a cross corner pattern to a final torque of 200 ft. lbs. (2400 in. lbs.).

Part Replacement Guide

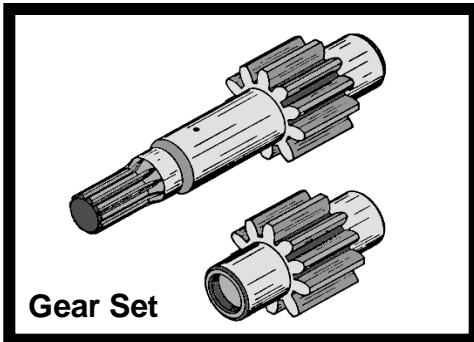

If the Gear Set contains any of the following defects, it should be replaced:

- Wear on the hubs or in the seal areas detectable by touch or in excess of .002”.
- Score marks, grooves, or burrs on the outside diameter of the teeth.
- Nicks, grooves, or fretting of the teeth surfaces.
- Wear or damage to the drive spline, key, or keyway.

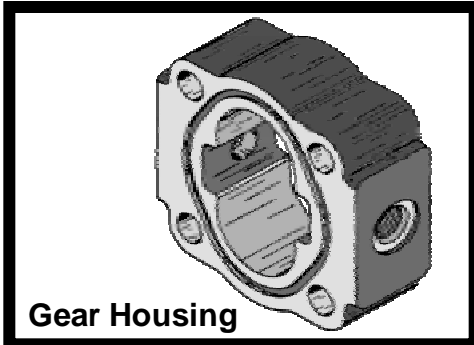

Wear in excess of .005” cut-out necessitates replacement of the gear housing. Place a straight-edge across the bore. If you can slip a .005” feeler gage in the cut-out area, replace the gear housing.

Where the cut-out is moderate, .005” or less, the gear housing is still in good condition. If the housing has equal size ports or no ports, the housing may be flopped 180° (exchanging ports) and reused.

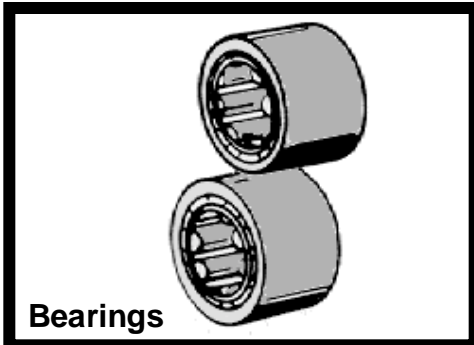

If the gears are replaced, then the bearings must be replaced also. Bearings should fit into the bores with a light press fit.

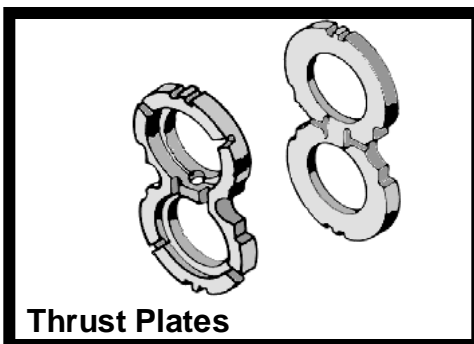

Any scratches, grooves, erosions, or pitting on the thrust plate face, the area that comes in contact with the gear faces, necessitates the replacement of the thrust plates.

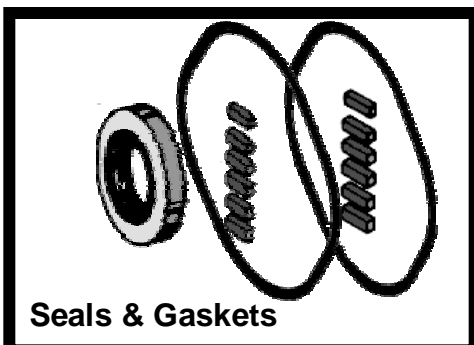

Replace all rubber and polymer seals whenever disassembling the pump. This includes lip seal, pocket seal strips, and section seals.

Tool List

- Arbor press
- Permanent Marker or an Awl
- Bearing puller (Owatonna Tool Co. MD- 956 or equivalent)
- Clean lint free cloths
- Deburring tool (file with the cutting teeth ground off)
- Machinist’s hammer
- Soft faced hammer
- Permatex Aviation Form-A-Gasket No.3 Non-hardening Sealant or equivalent
- Medium grit carborundum stone
- Hydraulic oil and grease
- Prick punch or machinists ink
- Sharp razor blade
- Scale (1/32” or 1/64” graduations)
- Feeler gauges
- Small screw driver
- Large screw drivers
- Torque wrench
- 13/16” socket
- 1½” steel ball
- Loctite® No.262
- Vise with a 6” minimum open spread
- Lip seal installation bar (1 3/4” X 2”)
- Shaft installation sleeve (steel)
- Lip seal removal tool
- Check tool
- 6” wrench

Lip Seal Removal Tool

A Seal removal tool can be easily made from an old screw driver. Heat the tip and bend as shown. Grind off the tip to fit the notch behind the lip seal.

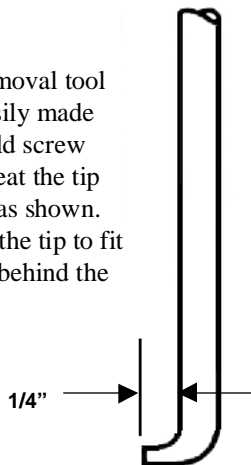

Check Tool

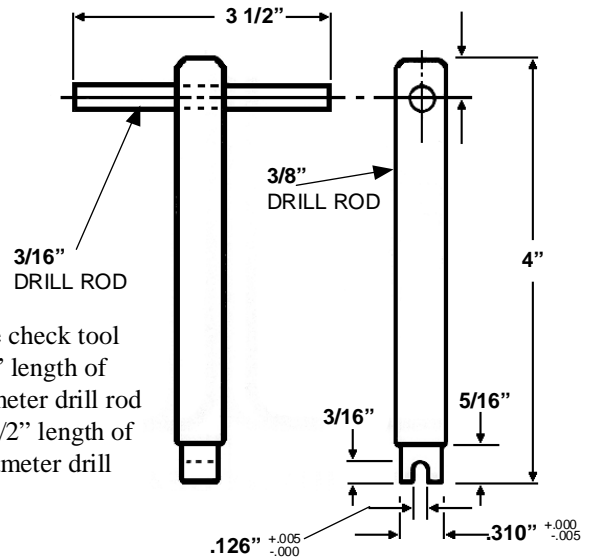

Make the check tool from a 4” length of 3/8” diameter drill rod and a 3 1/2” length of 3/16” diameter drill rod.

Shaft Installation Sleeve (steel)

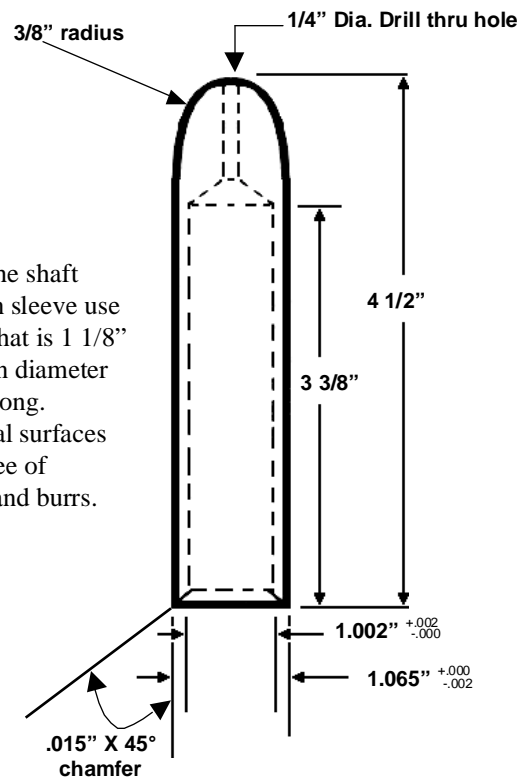

To make the shaft installation sleeve use bar stock that is 1 1/8” or 1 1/4” in diameter by 4 5/8” long. All external surfaces must be free of scratches and burrs.

Lubrication and Oil Recommendations

All parts, with the exception of the outboard bearing, are lubricated by the hydraulic oil in the circuit. Particular attention must be paid to keep the oil in the system clean. Whenever there is a pump or motor failure and there is reason to suspect that metal particles may be in the system, the oil must be drained, the entire system flushed clean, and any filter screens thoroughly cleaned or replaced. New oil should be supplied for the entire system. Oil suitable and recommended for use in circuits involving Commercial's pumps and motors should meet the following specifications:

- Viscosity:**
- 50 SSU minimum @ operating temperature
7500 SSU maximum @ starting temperature
 - 150 to 225 SSU @ 100° F (37.8° C) (generally)
44 to 48 SSU @ 210° F (98.9° C) (generally)

| Approximate SSU at . . . | | |
|--------------------------|-------------------|------------------|
| Oil Grade | 100° F (37. 8° C) | 210° F (98.9° C) |
| SAE 10 | 150 | 43 |
| SAE 20 | 330 | 51 |

Viscosity Index: 90 minimum

Aniline Point: 175 minimum

Recommended Additives: Foam Depressant
Rust and Oxidation Inhibitors

Other Desirable Characteristics:

- Stability of physical and chemical characteristics.
- High demulsibility (low emulsibility) for separation of water, air, and contaminants.
- Resistant to the formation of gums, sludges, acids, tars, and varnishes.
- High lubricity and film strength.

General Recommendations:

A good quality hydraulic oil conforming to the characteristics listed above is essential to satisfactory performance and long life of any hydraulic system.

Oil should be changed on regular schedules in accordance with the manufacturer's recommendations and the system should be periodically flushed.

Lubrication and Oil Recommendations

Oil temperature in reservoir must not exceed 200° F (93.3° C) with a maximum temperature of 180° F (82.2° C) recommended. Higher temperatures will result in rapid oil deterioration.

Reservoir capacity should equal in gallons the pump output in gpm or the total gpm of all pumps where there is more than one in the system.

Normal Temperatures:

0° F (-18° C) to 100° F (37.8° C) Ambient

100° F (37.8° C) to 180° F (82.2° C) System

Be sure your oil is recommended for the temperatures you expect to encounter.

Cold Weather Operation

Oils for use in cold weather should have a viscosity that does not exceed 7500 SSU at the minimum start-up temperature. A pour point of at least 20° F below start-up temperature is recommended. Start-up procedures should allow for a gradual warm-up until the oil reaches a reasonably fluid state.

The Use of Other Oils

- Diesel Fuel or Kerosene (Coal Oil): These are sometimes used as dilutants for cold weather operations but are not recommended as they are not sufficiently refined products.
- Fire Resistant Fluids: Of the several different types, only the inverted emulsion types may be used without changing to special seal, packing, gasket, hose, etc., compositions. Their use may substantially reduce pump life. Experience indicates that the use of fire resistant fluids can be disastrous unless certain precautions are followed. **DO NOT USE ANY FIRE RESISTANT FLUIDS OR NON-PETROLEUM OILS WITHOUT CONSULTING OUR PRODUCT SUPPORT DEPARTMENT.**
- These suggestions are intended as a guide only.
OBTAIN YOUR FINAL OIL RECOMMENDATIONS FROM YOUR OIL SUPPLIER.

Oil Cleanliness

Commercial suggests the use of a 25 micron, or better, return line filter in systems operating at 2500 psi/172 bar or less. In systems operating up to 3000 psi/207 bar a 15 micron filter is recommended. An ISO cleanliness level of 17/14 is required.

New oil being poured into the reservoir should be pre-filtered. Pour only clean oil from clean containers into the reservoir. A 100 mesh screen should generally be used in the suction line leading to the pump. The suction screen should be of sufficient size to handle twice the pump capacity. It must be cleaned and checked regularly to avoid damage due to contamination and cavitation.

Recommended Start-up Procedure for New or Rebuilt Pump or Motor

Before installing a new or a rebuilt pump or motor, back off the main relief valve until the spring tension on the adjusting screw is relaxed. This will avoid the possibility of immediate damage to the replacement unit in the event that the relief valve setting had been increased beyond the recommended operating pressure prior to removing the old unit.

Before connecting any lines to the pump or to the motor, fill all ports with clean oil to provide initial lubrication. This is particularly important when the unit is located above the oil reservoir.

After connecting the lines and mounting the replacement unit, operate the pump or the motor for at least two minutes at zero pressure at the lowest possible rpm. During this break-in period, the unit should run free and not develop an excessive amount of heat. If the unit operates properly, the speed and the pressure can then be increased to the normal operating settings.

Reset the main relief valve to its proper setting while the pump is running at the maximum operating engine (motor) speed for the vehicle.

**ALWAYS USE AN ACCURATE GAGE WHEN
ADJUSTING THE RELIEF VALVE PRESSURE
SETTING.**

Recommended Test Procedure

Be sure there is an adequate supply of oil for the pump, at least one gallon of oil for each gpm of pump capacity.

If one section of a tandem pump is being tested, make sure that all other sections that are not being tested are adequately supplied with oil. If any of the other sections run dry or if plugs are left in ports, serious and permanent damage will result.

The oil should be a good quality hydraulic oil rated at 150 SSU at 100° F with the oil temperature held at 120° F plus or minus 5° F (Test procedures are described in detail in SAE handbooks; see Hydraulic Power Pump Test Procedure SAE J745c.)

The feed line must be an adequate size with no more than 5" mercury vacuum adjacent to the pump inlet. As a rule, the feed line must provide a feed flow velocity that is not in excess of 8 feet per second.

Hot oil must not be fed into a cold pump. The pump could seize. Jogging could prevent seizure.

Operate the pump at least two minutes at zero pressure and at moderate speed (not over 1500 rpm).

If pump becomes hot to touch, it is binding and could seize. This doesn't happen very often, but if it does, the pump will have to be disassembled and be rebuilt with extra care taken to remove burrs and to assure freedom from binding.

Gradually increase the pressure on a pump intermittently until the desired test pressure has been reached. This should take about five minutes.

Delivery should run close to the rated catalog performance figures which are averaged from the testing of several pumps. A 5% lower reading may be used as a rated minimum if new or relatively new parts have been used. When rebuilding the pump with used parts from the original pump, that is only those parts which appear to be satisfactory for re-use, a 10% or 15% lower reading is permitted depending on the performance expected from the equipment. One's own experience will prove the best guide here.

Recommended Test Procedure

Many repairmen measure the output at the normal operating speed and at zero pressure, then again at 1000 psi (or the operating pressure of the equipment), and allow a volume decrease approximating the listing below. The table listing shows the drop off in flow that can be expected at various operating pressures for a pump rebuilt with used parts.

P20 pumps are generally tested to 2000 psi.

| GPM DELIVERY at 1800 rpm | GPM DROP OFF AT . . . | | | |
|---|------------------------------|-------------------------|-------------------------|-------------------------|
| | 1000 psi/70 bar | 1500 psi/105 bar | 2000 psi/140 bar | 2500 psi/175 bar |
| 100 psi | 2 to 3 | 2 ½ to 3 ½ | 3 to 4 | 3 ½ to 4 ½ |
| 5 – 14 | 2 ½ to 3 ½ | 3 to 4 | 3 ½ to 5 | 4 to 5 ½ |
| 15 – 25 | 3 to 4 | 4 to 5 | 4 to 6 | 4 ½ to 6 ½ |

At test speeds other than 1800 rpm, gpm delivery will vary almost proportionately, but the same (drop-off) figures should be used.

Be sure to run the pump in the direction for which it was designed and built. Driving the pump in the wrong direction will build up pressure behind the lip seal, causing damage to the pump, and necessitating the replacement of the pump.

Since it is rarely feasible to test motors on dynamometers, the practical procedure is to test them as pumps, running complete testing procedures in each direction.

After completing the testing procedures, the pump is ready for installation and immediate duty operation on equipment. Again, it must be remembered that to prevent seizure, hot oil must not be fed into a cold pump.

Instructions for Rotation Change

The P20 series pump can be assembled for clockwise (CW), counterclockwise (CCW), or bi-rotational operation. The direction of rotation is determined by looking at the pump with the drive shaft facing you and the idler gear down. If the pump has unequal porting and the larger port is on the left side, then the pump is set up for CW operation. If the larger port is on the right side of the pump, then it is set up for CCW operation. Bi-rotational pumps, that can be run in either direction, will have equal size ports.

Disassembly

- 1) If the unit has a keyed shaft remove the key.
- 2) Clamp the unit in a vise with the drive shaft down.
- 3) Remove the cap screws on single units or hex nuts and studs on multiple units.
- 4) Remove the port (rear) end cover.
- 5) Remove the gear housing and the gear set. Keep the gears together because they are a matched set.

For multiple units: Remove the bearing carrier and the next gear housing and gear set until all that remains is the shaft end cover.

Note: Care should be taken to avoid losing the small rubber pocket seals fitted in the thrust plate pocket seal grooves.

- 6) Lift the thrust plate off of the shaft end cover. Do not lose the pocket seals.
- 7) Remove the check plug in the shaft end cover with a screwdriver and then install it in the opposite drain hole. Screw in tightly and stake the check plug with a punch at both edges of the screwdriver slot. For a single rotation pump the check plug is always located on the high pressure (outlet) side of the pump. If the shaft end cover has two check plugs leave as is; the pump is already set-up for double rotation.

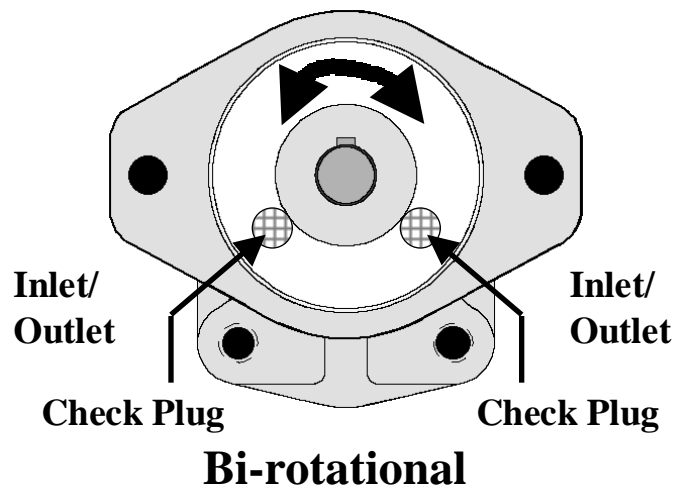
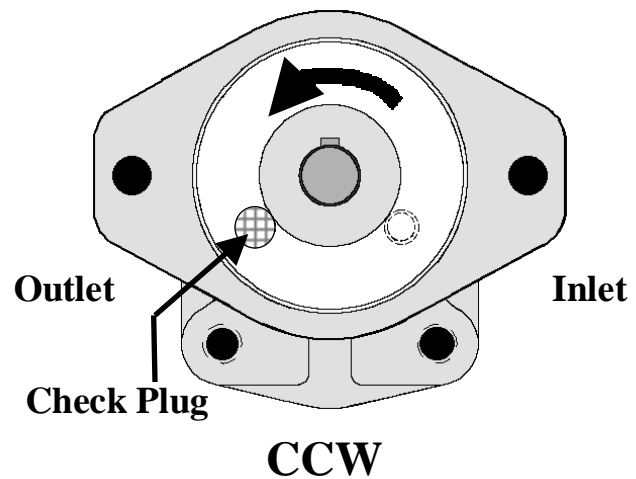
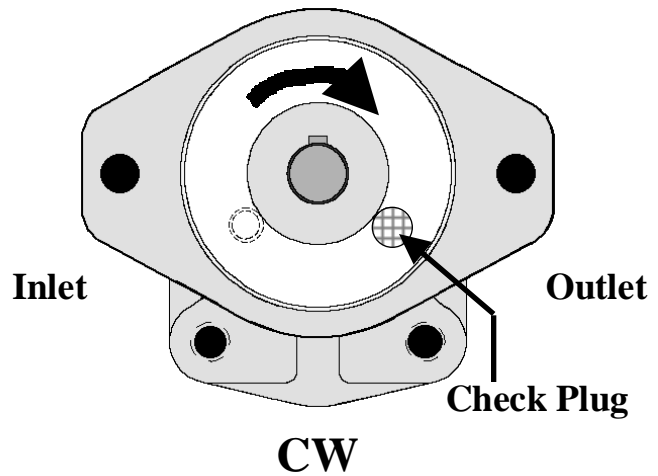

Instructions for Rotation Change

Assembly

- 1) Before assembly of the unit stone off the machined surfaces. This will remove any nicks or burrs that may have resulted from the disassembly.
- 2) Air blast all parts and wipe them with a clean lint free cloth before starting the assembly.

Note: P20 series thrust plates are designed for bi-rotational operation and do not have to be rotated.

- 3) Place one thrust plate with pocket seals over the shaft end cover bearings. Be sure the pocket seals are properly fitted in the thrust plate pocket seal grooves.
- 4) Insert the gear shaft with the shaft installation sleeve into the shaft end cover with a twisting motion. Insert the idler gear.
- 5) Flip the gear housing 180° and carefully slide over the gear set. See figure 1. Make sure both section seals stay in the seal grooves during assembly. Keep the drive gear and idler gear in the same gear bore as before.
- 6) **For multiple units:** Place the thrust plates with pocket seals over the bearings on both sides of the bearing carrier. Be sure that the pocket seals are properly fitted in the thrust plate pocket seal grooves.
- 7) Flip the bearing carrier 180° and install over the gear set and gear housing.

Note: If the bearing carrier has an L-shaped porting configuration, it cannot be used. A new bearing carrier will have to be machined with the proper configuration.

- 8) Insert the gears into the bearing carrier.
- 9) Flip the gear housing 180° and carefully slide over the gear set. Make sure both section seals stay in the seal grooves during assembly.

- 10) Place the port end cover with the thrust plate over the gear set. If the port end cover is ported, rotate 180°.
- 11) Insert the cap screws or the studs into the unit and torque in a cross corner pattern to 2400 in. lbs..

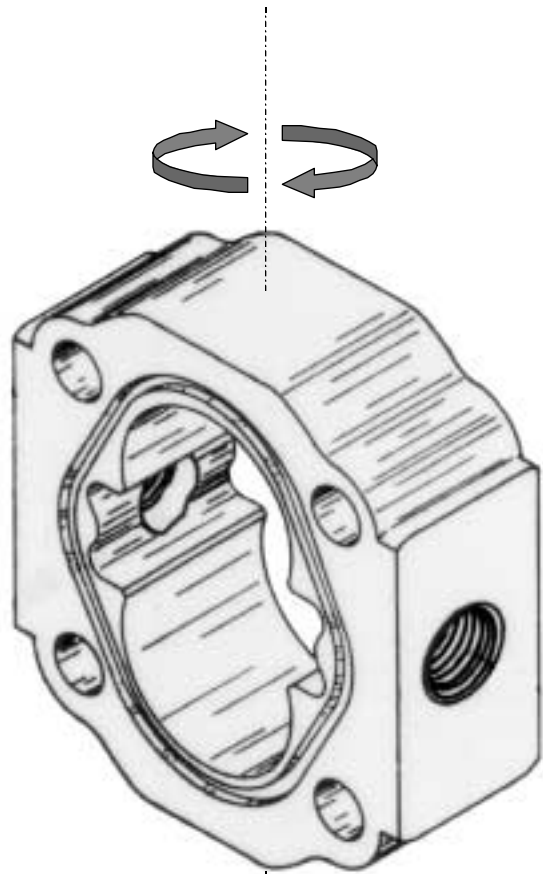

Figure 1

Pump Division



Commercial
Intertech

1775 Logan Ave.
P.O. Box 239
Youngstown, Ohio 44501
(330) 746-8011 • FAX (330) 746-1148

Commercial Intertech Corp. is an international manufacturer of hydraulic systems and their component pumps, motors, valves and cylinders.

